

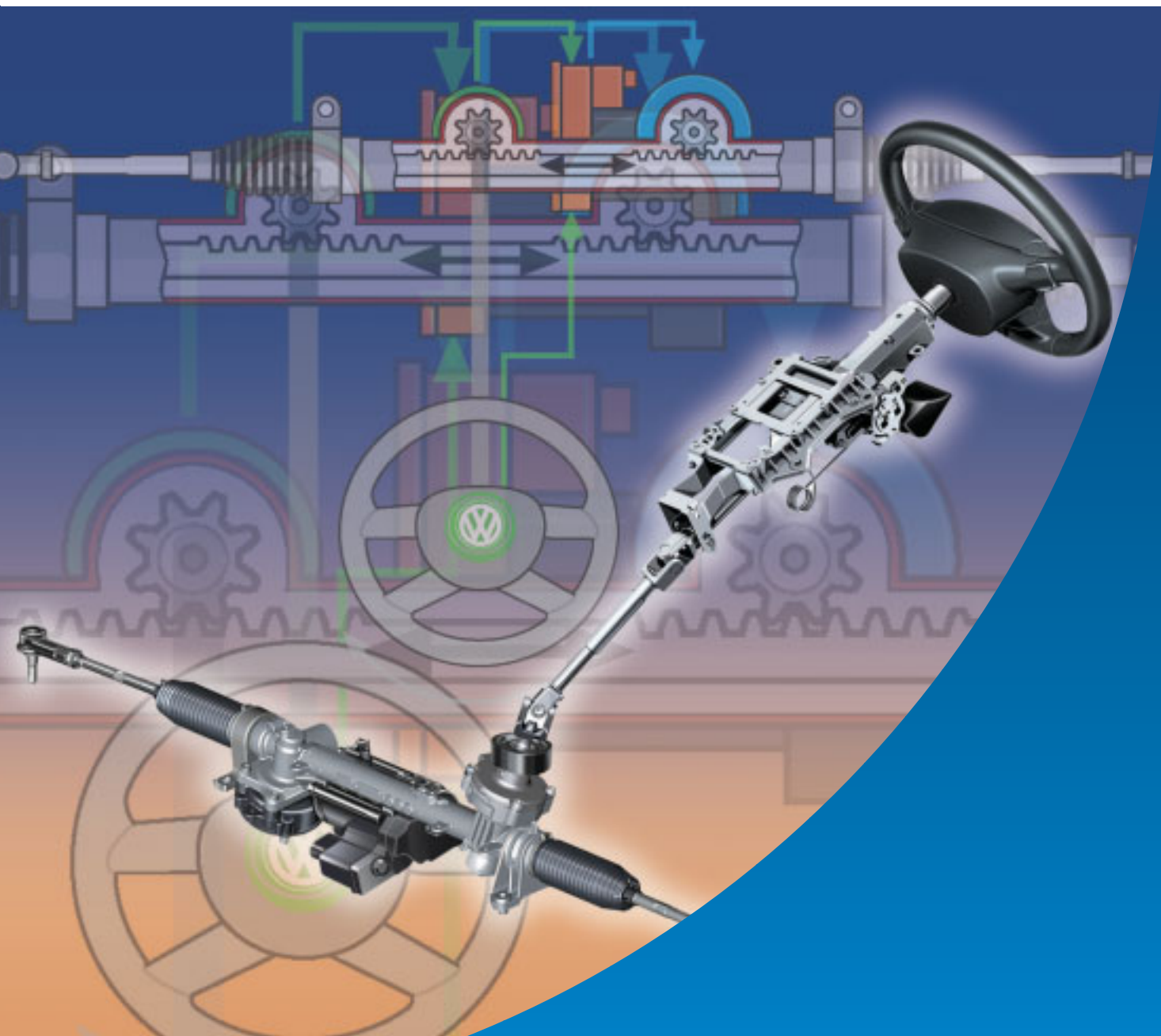

Self-study programme 317

The electro-mechanical power steering with dual pinion

Design and function



The electro-mechanical power steering has many advantages over the hydraulic steering system. It supports the driver and thereby provides physical and mental driving relief. This is achieved by the input response feature, which means that the steering is only power assisted when the driver so wishes.

Power steering assistance depends on the road speed, the amount of steering force applied and the steering angle. How the electro-mechanical power steering works in detail is described in this self-study programme.

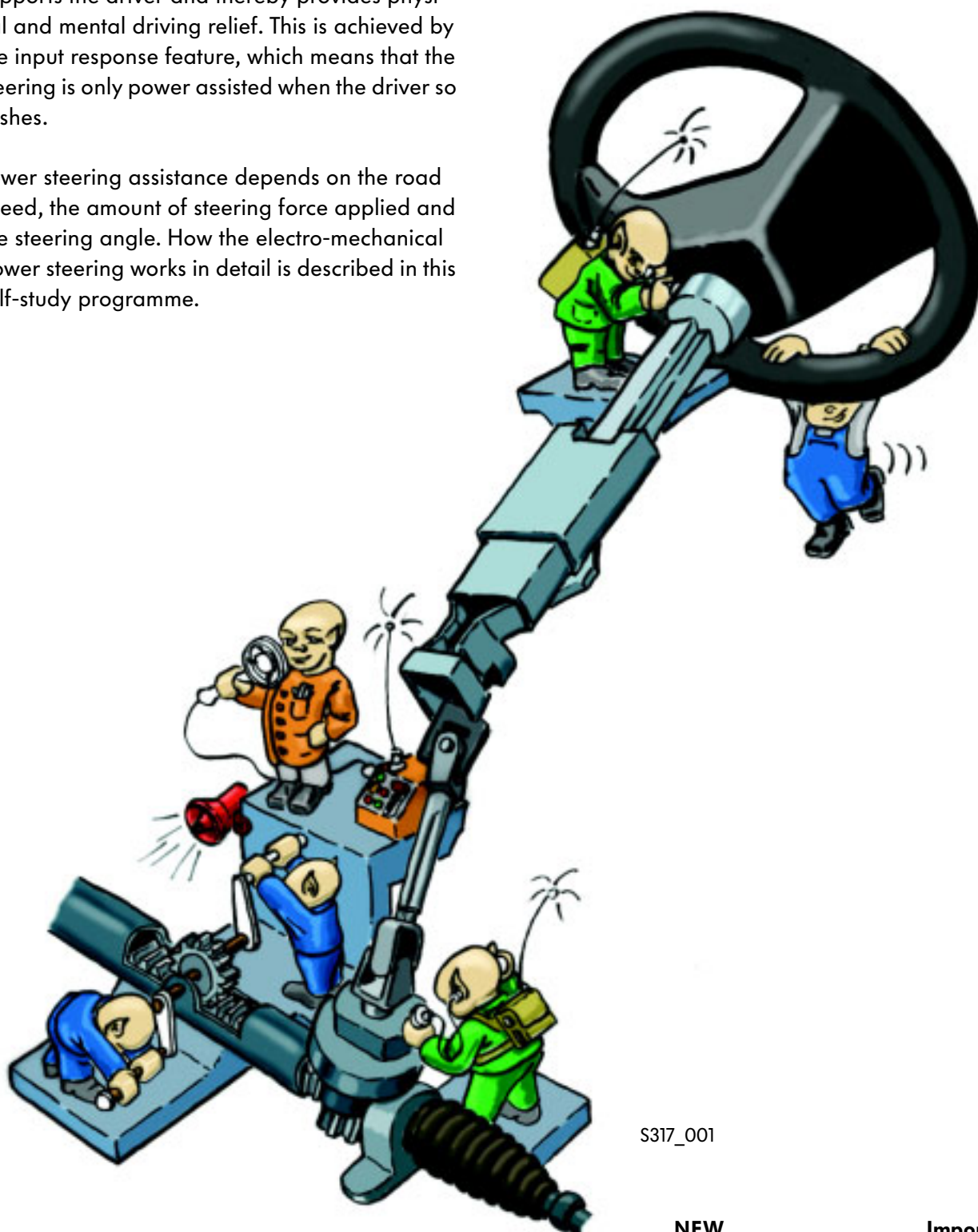

S317_001

NEW



Important Note



**This self-study programme shows the design and function of new developments!
The contents will not be updated.**

For current inspection, adjustment and repair instructions, please refer to the relevant service literature.



| | |
|---------------------------------|-----------|
| Introduction | 4 |
| System overview | 8 |
| Function | 9 |
| Steering mechanics | 16 |
| Steering electrics | 17 |
| Functional diagram | 27 |
| Service | 28 |
| Test yourself | 30 |



Introduction

General overview of electro-mechanical power steering with dual pinion

The steering system components are:

- Steering wheel
- Steering column switch with steering angle sender G85
- Steering column
- Steering moment sender G269
- Steering gear
- Electro-mechanical power steering motor V187
- Power steering control unit J500

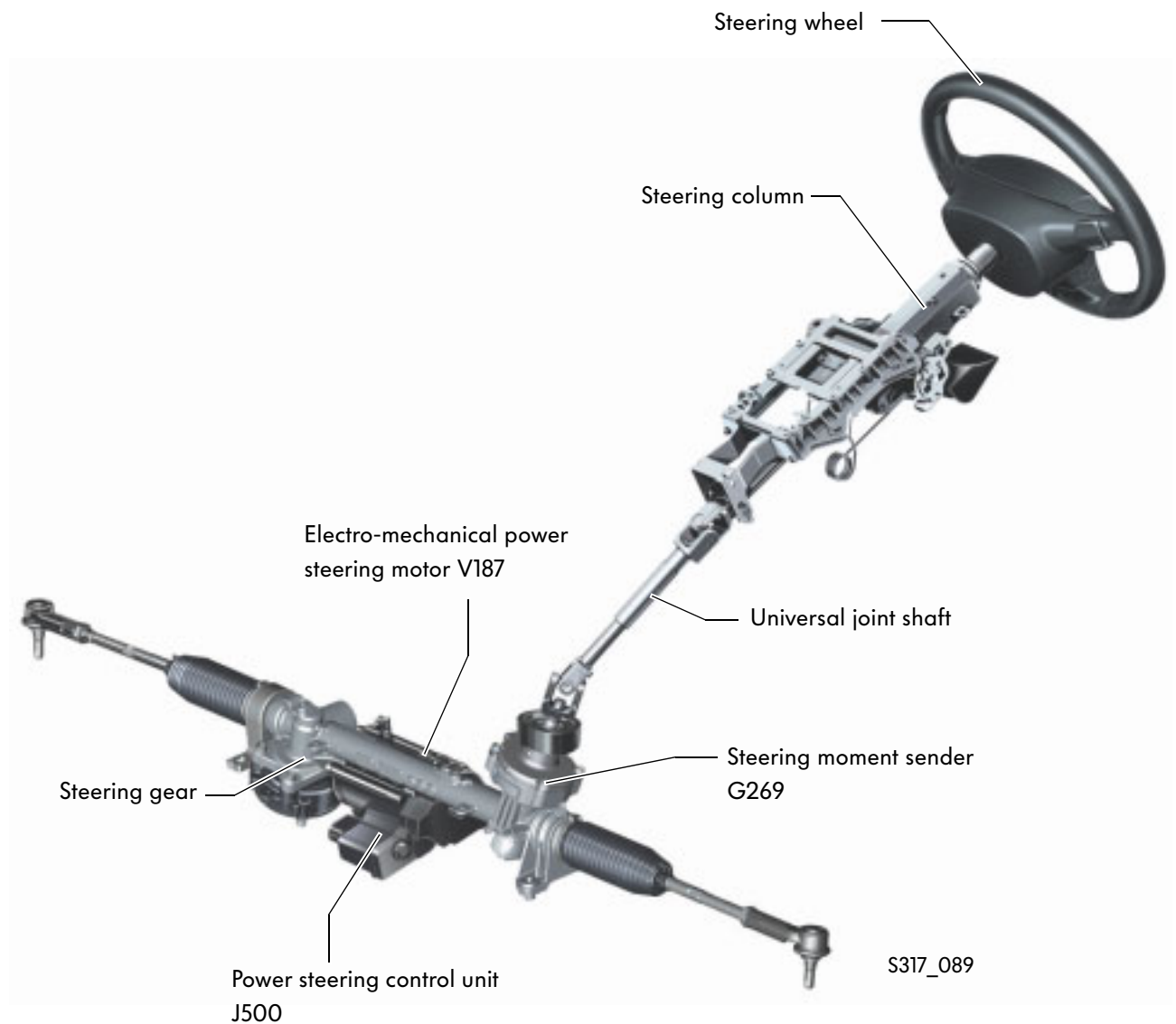



What you should know about the electro-mechanical power steering system:

With electro-mechanical power steering, there is no requirement for hydraulic assistance to support the steering. No hydraulic oil means that, with this steering system, an important contribution has been made towards environmental protection.



S317_106

The electro-mechanical power steering system is of the dual pinion type. This is characterised by two pinions (steering and drive pinions), which enable the necessary steering force to be transmitted to the steering rack.

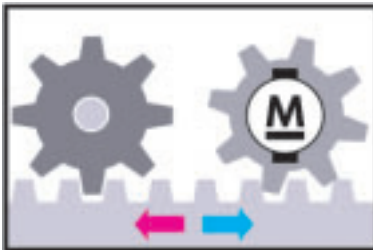

S317_108

To assist the steering, an electric motor is actuated based on input response. The system provides the driver with assistance depending on the driving conditions (servotronic).

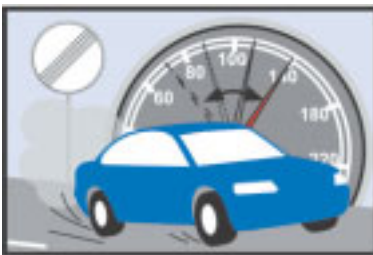

S317_110

The electro-mechanical power steering supports return of the steering wheel back to the centre position via the "active return" function. This results in a prominent well-balanced feeling and extremely accurate straight-line stability in every driving situation.

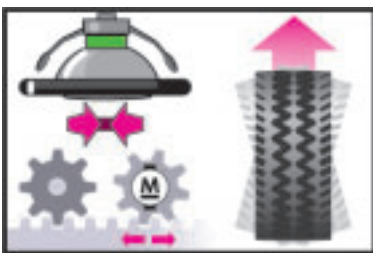

S317_111

With the straight-line stability function, a force is generated and applied to make it easier for the driver to steer the vehicle in a straight line when the vehicle is being affected constantly by side winds or driven up or down gradients.



S317_112

Introduction



The advantages of electro-mechanical power steering

One advantage of the electro-mechanical power steering, compared with hydraulically assisted steering systems, is that there is no requirement for a hydraulic system. This leads to further advantages, such as:

- no hydraulic components, for example power steering oil pump, hoses, oil tank, filter,
- no hydraulic fluid,
- saving of space in fitting location,
- reduction in noise,
- saving of energy,
- no complex hose and wiring system.

The components that assist steering are located on, and operate directly at, the steering gear.

This results in a notable saving in energy. Unlike hydraulically assisted steering, which requires a permanent circuit flow, the electro-mechanical power steering only draws energy when steering force is actually imparted. This input response performance leads to a reduction in fuel consumption.

The driver has an optimal driving feeling in every situation thanks to

- good straight-line stability (return of the steering wheel to the centre position is supported actively by the electro-mechanical power steering system),
- direct but soft application of the steering input
- no uncomfortable steering reactions over uneven driving surfaces.



The saving in energy over 100 kilometres is up to 0.2 litres.

The electro-mechanical power steering and its individual parts

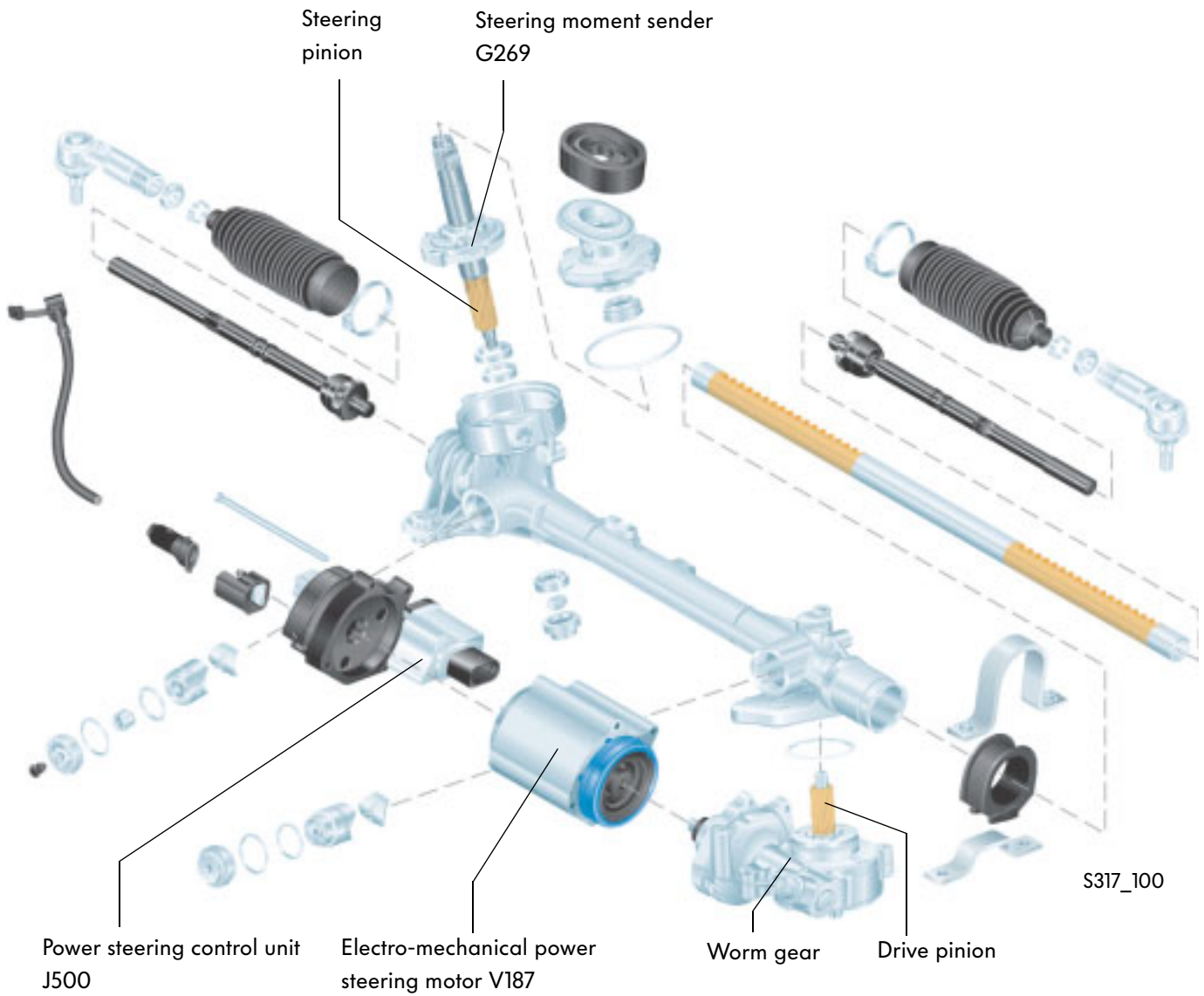

System overview

System overview

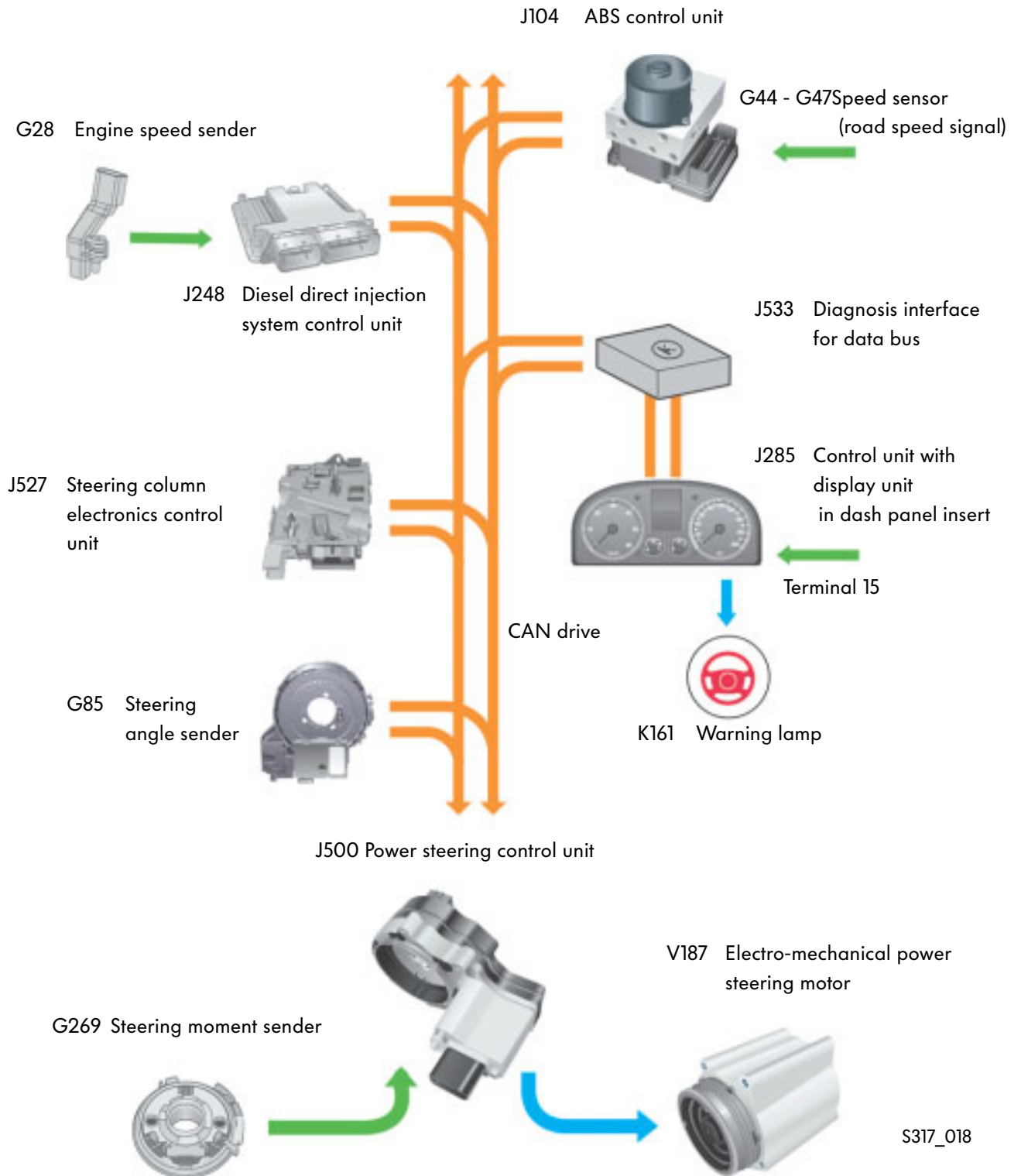

The map and the map characteristics

Steering assistance is controlled via a map, which is stored permanently in the program memory of the control unit. The memory has a capacity for up to 16 different maps. In the Golf 2004, for example, 8 of the total available maps are used.

Maps are activated in the factory depending on requirements (e.g. vehicle weight).

However, maps can also be activated in a Service Centre using the vehicle diagnosis, testing and information system VAS 5051 via the "adaption" function and "channel 1" command. This would become necessary, for example, if the control unit or steering system were to be renewed.

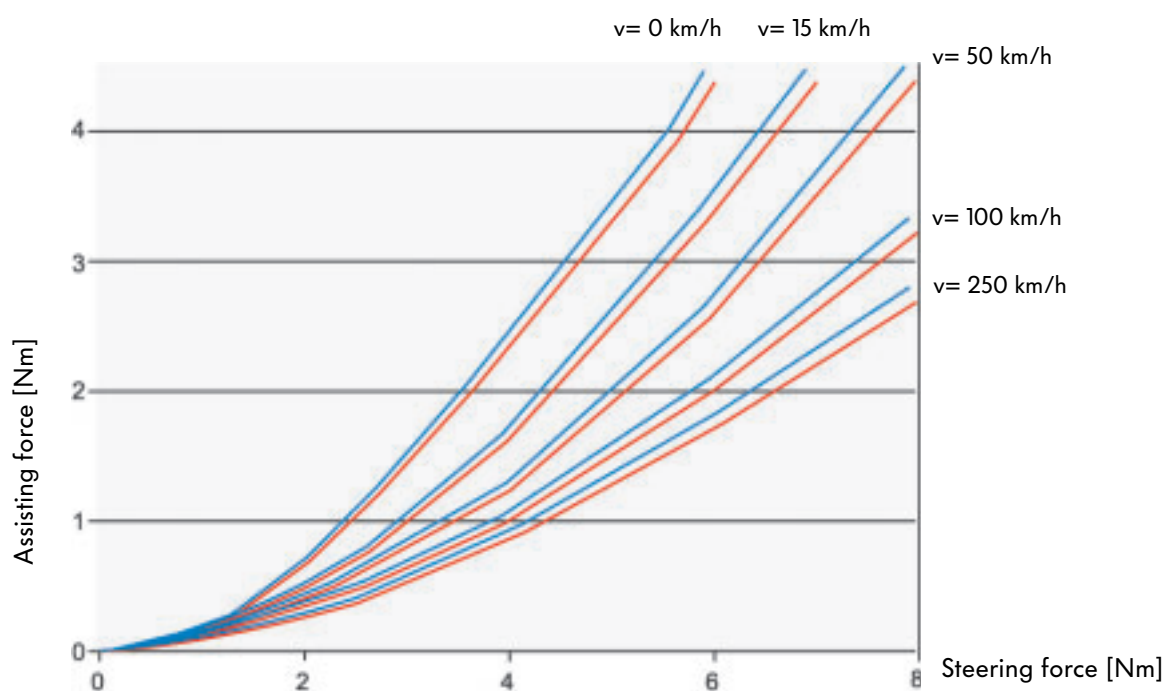

S317_022

As an example, and from the 8 maps available for the Golf 2004, one map is selected for a heavy vehicle and one for a light vehicle.

- Heavy vehicle
- Light vehicle

One map consists of five different map characteristics for different speeds. (e.g. 0 km/h, 15 km/h, 50 km/h, 100 km/h and 250 km/h). One map characteristic determines, for your speed, which amount of steering assistance is imparted by means of the electric motor at which steering wheel force.

Function

The steering function

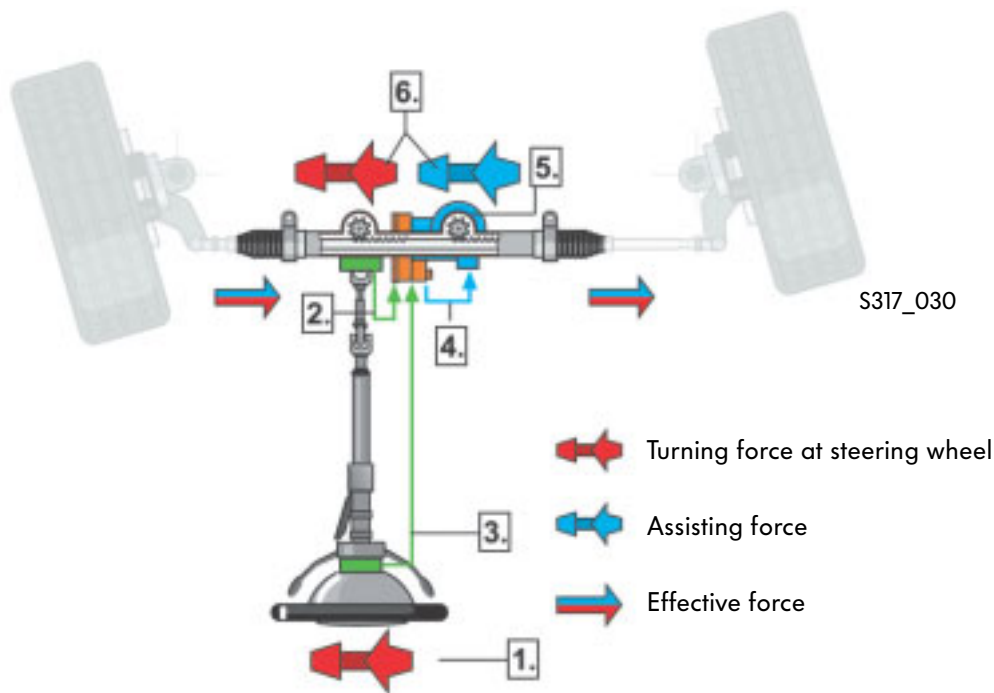

1. The power steering assistance starts when the driver uses force to turn the steering wheel.
2. The force on the steering wheel causes a torsion bar in the steering gear to turn. The power steering sender G269 detects the rotation and sends the calculated steering force figure to the control unit J500.
3. The steering angle sender G85 reports the current steering angle and the rotor speed sender reports the current steering speed.
4. Depending on the steering force, road speed, engine speed, steering angle, steering speed and maps stored in the control unit, the control unit calculates the necessary assisting force and actuates the electric motor.
5. The steering assistance comes from a second pinion, which imparts its energy in parallel on the steering rack. This pinion is driven by an electric motor. The motor engages in the steering rack via a worm gear and drive pinion and thereby transmits the force required for steering assistance.
6. The sum of the turning force on the steering wheel and the assisting force is the effective force applied on the steering gear to move the rack.

The steering function for parking manoeuvres

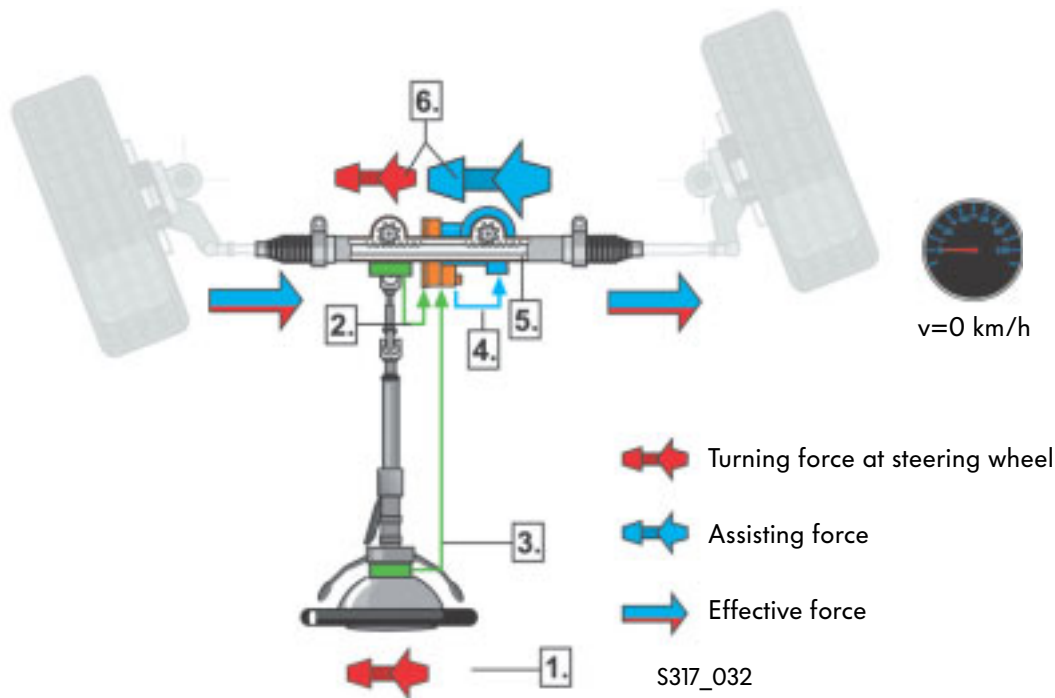

1. When parking the vehicle, the driver turns the steering wheel rapidly.
2. The torsion bar is turned. The steering moment sender G269 picks up the rotation and sends a signal to the control unit J500, indicating that a large amount of force has been placed on the steering wheel.
3. The steering angle sender G85 reports a large steering angle and the rotor speed sender reports the current steering speed.
4. Based on the large amount of steering force, the road speed of 0 km/h, the engine speed, the large steering angle, the steering speed and the maps stored in the control unit for $v=0$ km/h, the control unit detects that a large amount of assisting force is required and actuates the electric motor.
5. In this way, the largest amount of steering assistance is imparted on the steering rack via the second pinion and in parallel for parking manoeuvres.
6. The sum of the turning force on the steering wheel and the maximum assisting force is the effective force applied on the steering gear for movement of the rack during parking manoeuvres.



Function

The steering function in urban areas

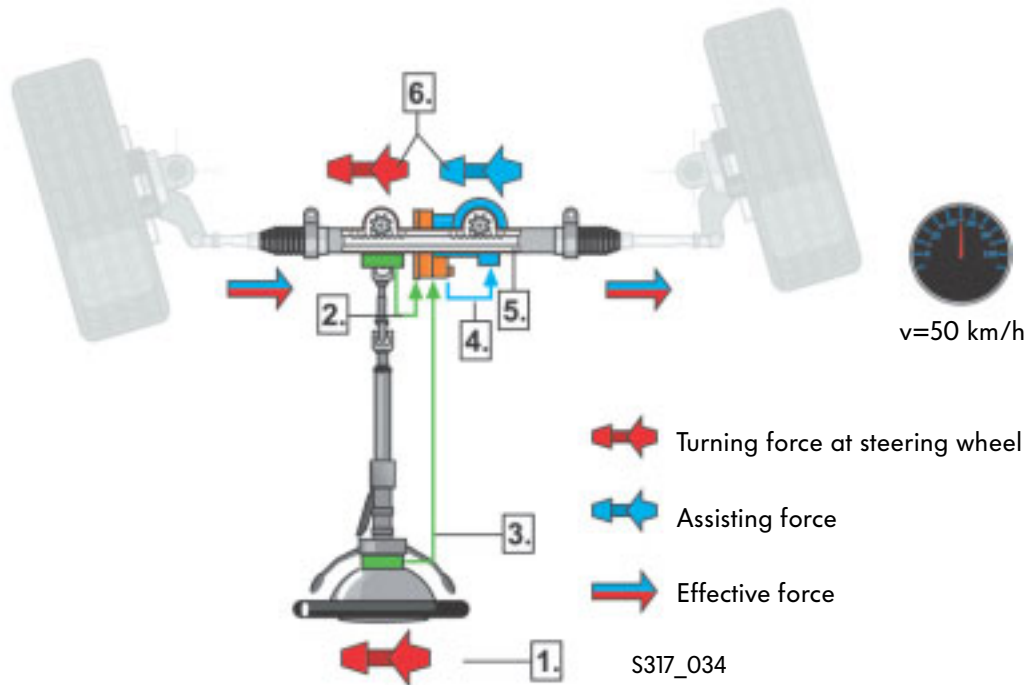

1. When cornering in urban areas, the driver uses force to turn the steering wheel.
2. The torsion bar is turned. The steering moment sender G269 picks up the rotation and sends a signal to the control unit J500, indicating that a medium amount of force has been placed on the steering wheel.
3. The steering angle sender G85 reports a medium steering angle and the rotor speed sender reports the current steering speed.
4. Based on the medium amount of steering force, the road speed of 50 km/h, the engine speed, the medium steering angle, the steering speed and the maps stored in the control unit for v=50 km/h, the control unit detects that a medium amount of assisting force is required and actuates the electric motor.
5. In this way, a medium amount of steering assistance is imparted on the steering rack via the second pinion and in parallel during cornering.
6. The sum of the turning force on the steering wheel and the medium assisting force is the effective force applied on the steering gear for movement of the rack during cornering in urban areas.

The steering function on motorways

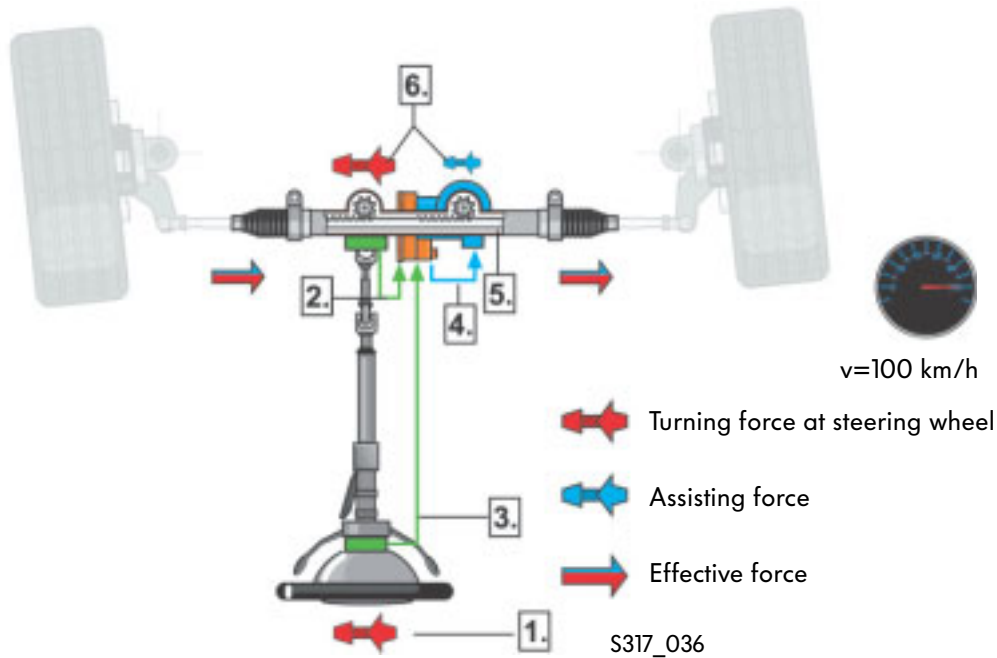

1. To change lanes, the driver imparts light force on the steering wheel.
2. The torsion bar is turned. The steering moment sender G269 picks up the rotation and sends a signal to the control unit J500, indicating that a small amount of force has been placed on the steering wheel.
3. The steering angle sender G85 reports a small steering angle and the rotor speed sender reports the current steering speed.
4. Based on the small amount of steering force, the road speed of 100 km/h, the engine speed, the small steering angle, the steering speed and the maps stored in the control unit for $v=100$ km/h, the control unit detects that a small amount of assisting force is required and actuates the electric motor.
5. In this way, a small amount of steering assistance is imparted on the steering rack via the second pinion and in parallel during lane change manoeuvres on the motorway, or no assistance at all.
6. The sum of the turning force on the steering wheel and the minimum assisting force is the effective force applied on the steering gear to move the steering rack during lane changing manoeuvres.



Function

The active return function

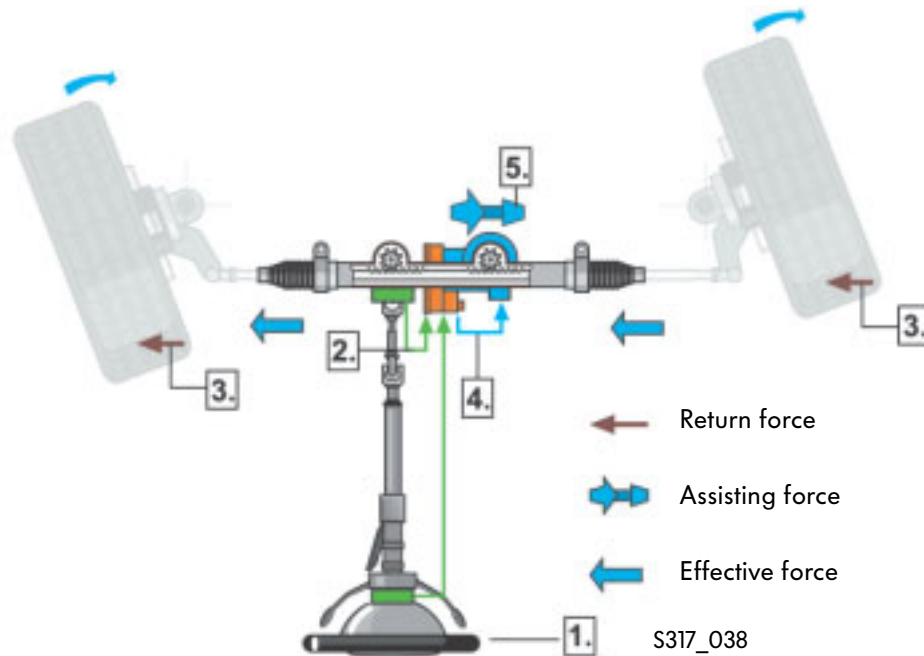

1. If the driver reduces the force on the steering wheel during cornering, torsion bar tension is relieved.
2. In conjunction with the reduced steering force, inclusion of the steering angle and the steering speed, a return speed specification is calculated. This is compared with the steering angle speed. The result of this is the returning force required.
3. Return forces are imparted on the steering wheels as a result of the running gear layout. The return forces are often too weak, due to friction in the steering system and in the axle (suspension), to bring the wheels back to the centre position.
4. The control unit calculates the necessary return force required from the electric motor by evaluating the steering force, road speed, engine speed, steering angle, steering speed and the map characteristics stored in the control unit.
5. The motor is actuated and the wheels are returned to the straight ahead position.



Straight-line stability

Straight-line stability is an extension of the active return function. An assisting force is generated here to bring the wheels of the vehicle in the centre position, when no force is applied. To do this, a difference is made between a short period algorithm and a long period algorithm.

Long period algorithm

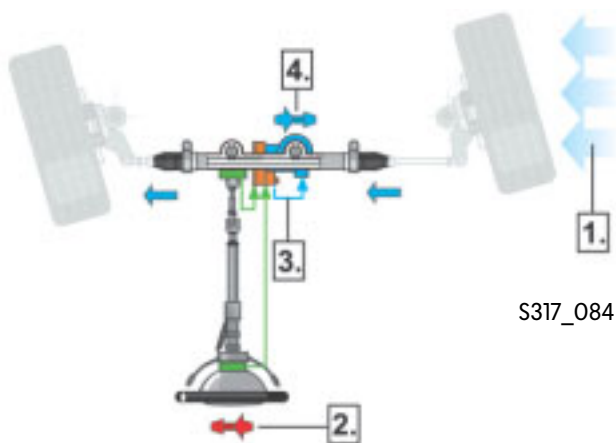
The long period algorithm has the task of balancing deviations either side of the centre position that occur over a long period of time. For example, deviations that could be caused when summer tyres are changed for winter tyres (used).



-  Return forces
-  Assisting force
-  Effective force

Short period algorithm

The short period algorithm is responsible for correcting deviations that occur briefly. This makes driving easier for the driver when, for example, permanent side winds make it necessary to steer against a resistance.

1. A constant side force is imparted on the vehicle, e.g. side wind.
2. The driver applies force on the steering wheel to keep the vehicle in a straight line.
3. The control unit calculates the necessary force required from the electric motor to maintain the straight ahead position by evaluating the steering force, road speed, engine speed, steering angle, steering speed and the map characteristics stored in the control unit.
4. The motor is actuated. The vehicle is brought into the straight ahead position. The driver no longer has to steer against the resistance.



Steering mechanics

The steering gear



The steering gear consists of a steering moment sender, a torsion bar, a steering and drive pinion, a worm gear and an electric motor with control unit. The core of the electro-mechanical power steering is a steering rack with two teeth engaged in the steering gear.



On the electro-mechanical power steering with dual pinion, the steering force required is transferred via the steering pinion and the drive pinion onto the steering rack. The steering pinion transfers the steering force applied by the driver and the drive pinion transfers the assisting force from the electro-mechanical power steering motor via a worm gear.

The electric motor with control unit and steering assistance sensors can be found on the second pinion. This design means that there is a mechanical connection between the steering wheel and steering rack. In this way, the vehicle can still be steered mechanically in the event of failure of the servo motor.

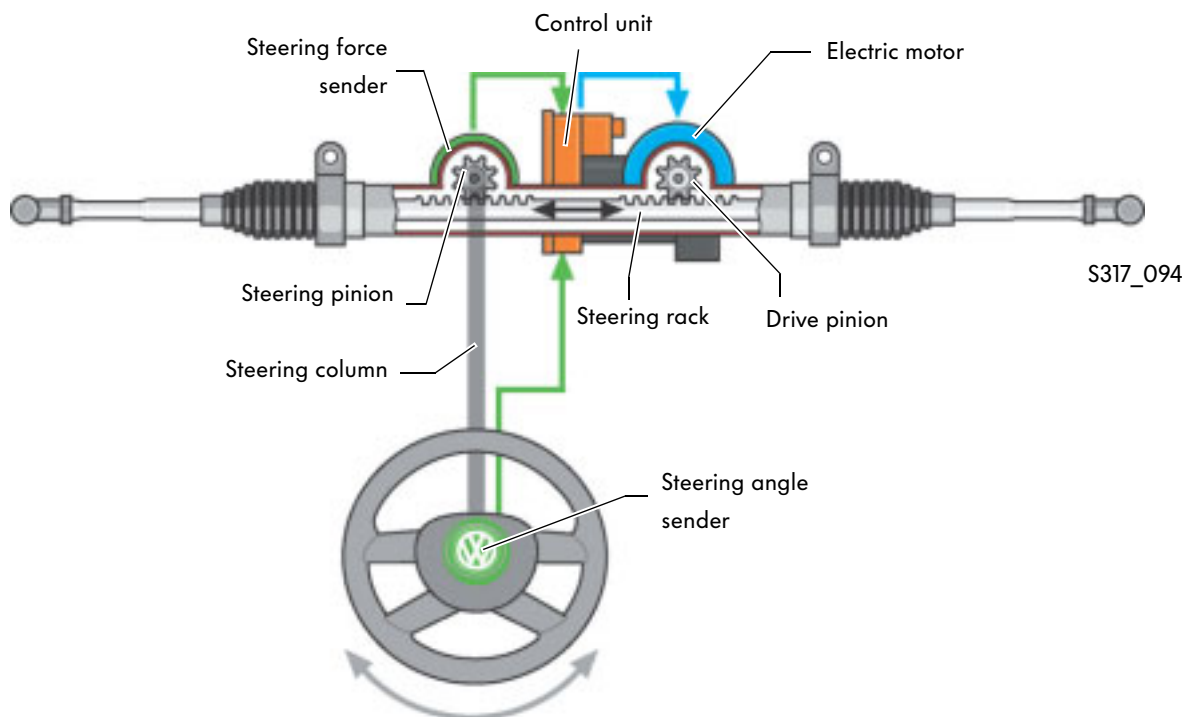

Steering angle sender G85

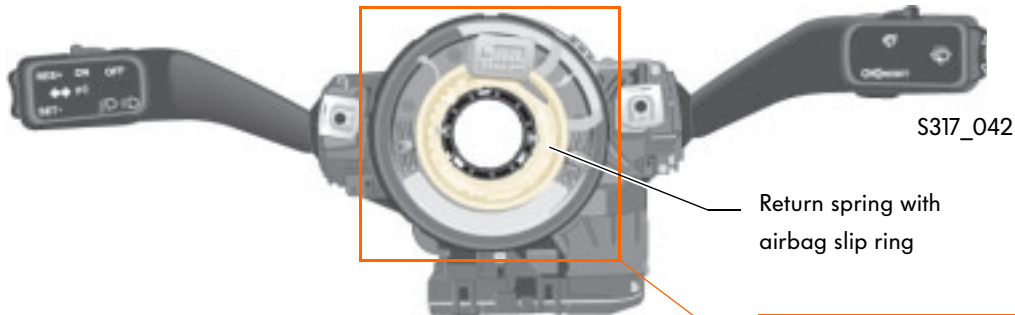

The steering angle sender G85 can be found behind the return spring with airbag slip ring. It is located on the steering column between steering column switch and steering wheel.

It sends the signal for steering angle analysis to the steering column electronics control unit J527 via the CAN data bus.

Located in the steering column electronics control unit is the electronic system for analysis of the signals.

Effects of failure

In the event of signal failure, an emergency running program is started. The missing signal is replaced by a substitute figure.

Power steering assistance remains intact. Warning lamp K161 will light up to indicate the fault.

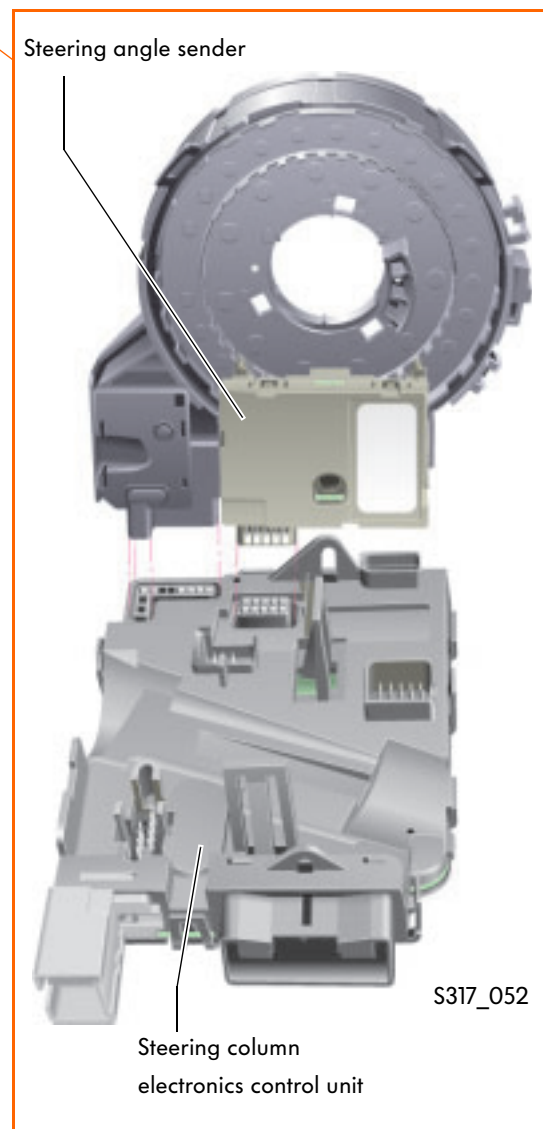

Steering electrics

Principles of operation

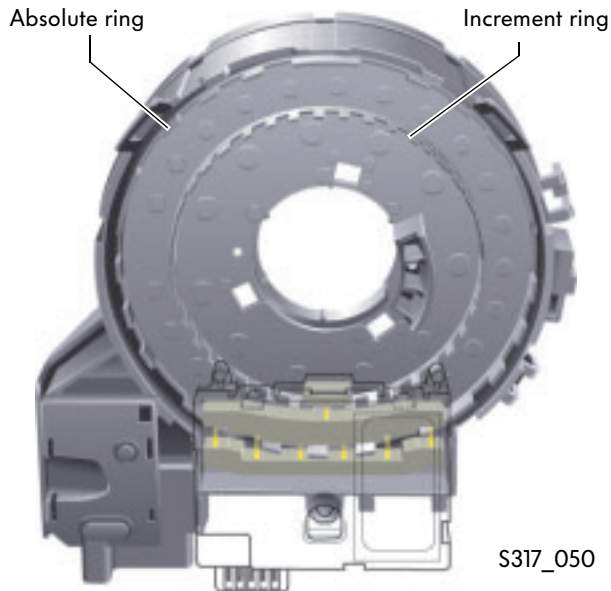

Basic components of the steering angle sender are:

- Code plate with two codes
- Photoelectric beam pairs, each with one light source and one optical sensor

The code plate consists of two rings, an outer absolute ring and an inner increment ring.

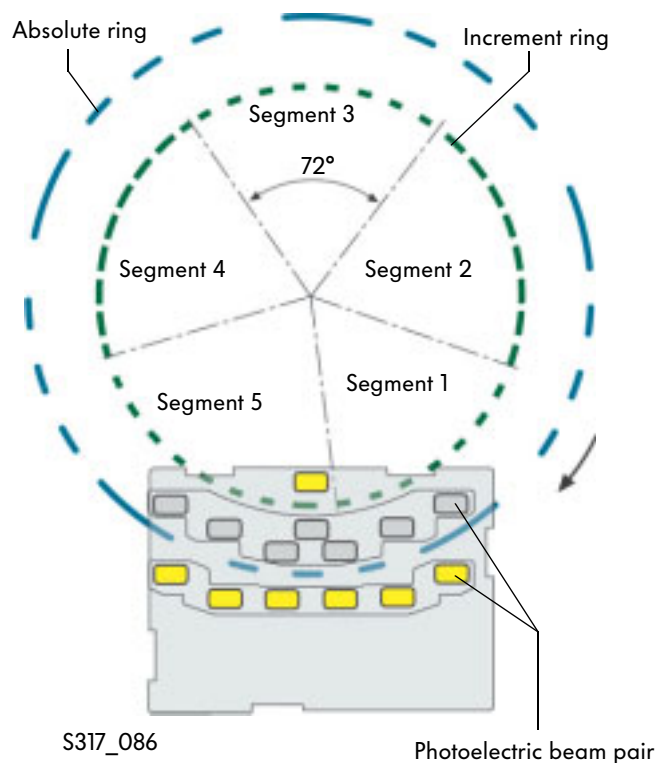

The increment ring is separated into 5 segments, each of 72° increments, and is read by a photoelectric beam pair. Within each segment the ring is split. The gap of the split is equal within the segments but different between the segments. This provides the code for the segments.

The absolute ring determines the angle. It is read by 6 photoelectric beam pairs.

The steering angle sender can detect a steering angle of up to 1044° . It accumulates the degrees after each turn of the steering wheel. In this way, it can detect that a full steering circle is complete when the 360° mark is exceeded.

The design of the steering gear allows 2.76 turns of the steering wheel.

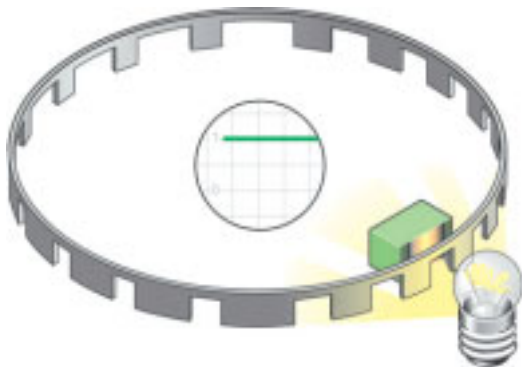

S317_114

Angle measurement is by means of the photoelectric beam principle.

If, for purposes of simplification, the increment ring is used as an example, the light source is on one side of the segment ring and the optical sensor is on the other.

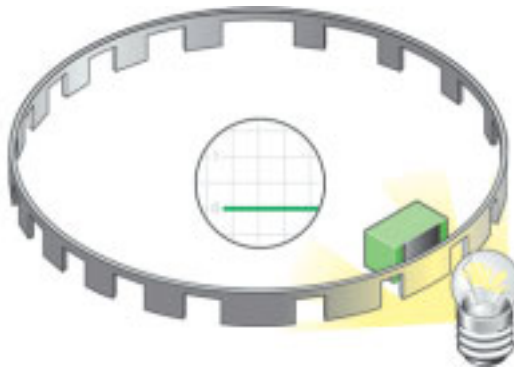

S317_116

When light shines through a gap onto a sensor, signal voltage is generated. When the light source is covered, voltage is interrupted again.

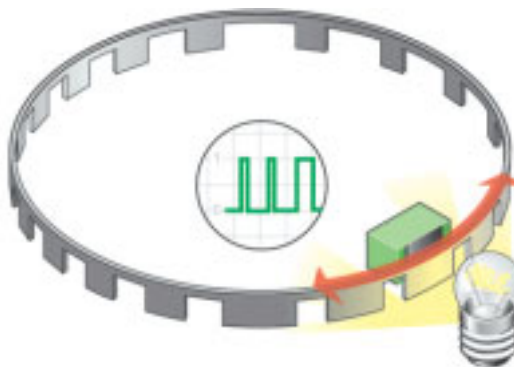

S317_118

If the increment ring is now moved, a sequence of signal voltages is given.

This is precisely how the sequence of signal voltages occurs on each photoelectric beam pair of the absolute ring.
All signal voltage sequences are processed by the steering column electronics control unit.

By comparing the signals, the system can calculate how far the rings have been moved. In this way, the starting point for movement of the absolute part is determined.



Steering electrics

Steering moment sender G269

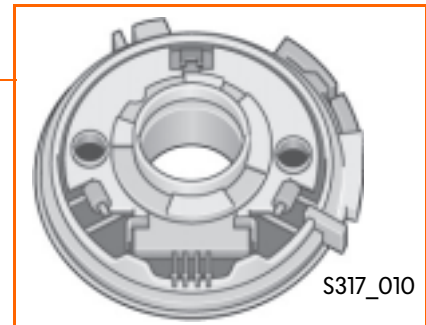
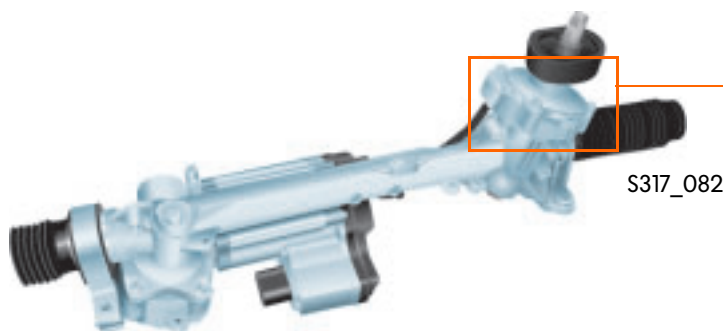

The steering force, or moment, is calculated directly at the steering pinion with help from the steering moment sender G269. The sensor works on the principle of magnetic resistance. It is of the twin (redundant) type construction to assure the highest level of safety.

The steering column and steering gear are joined together at the torque sensor via a torsion bar. The connecting piece at the steering column features a magnetic rotor, which turns about 24 areas of different magnetic polarity. For current evaluation, two terminals each are used.

The counterpart is a magnetic resistor sensor element, which is attached to the steering gear connecting piece.

If the steering wheel is turned, both connecting pieces move against each other, depending on the amount of force that is applied.

The magnetic rotor also moves against the sensor element during this period, which means that the steering force can therefore be measured and sent to the control unit as a signal.

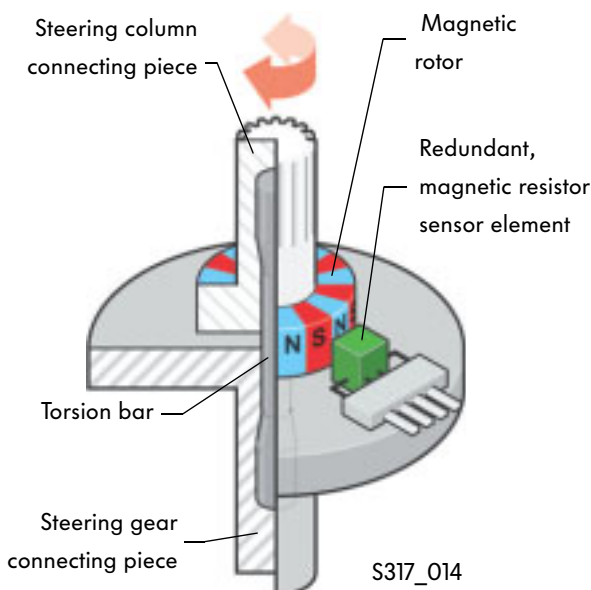

Effects of failure

In the event of failure of the steering moment sender, the steering gear must be renewed. If a fault is detected, the power steering assistance is shut down. This shut down is a soft and gradual process, rather than sudden. To achieve a soft and gradual shutdown, a substitute steering force signal is calculated in the control unit from the steering and rotor angle of the electric motor. Faults are indicated by warning lamp K161.

Rotor speed sender

The rotor speed sender is part of the electro-mechanical power steering motor V187. It cannot be accessed externally.

Signal application

The rotor speed sender operates on the principle of magnetic resistance and is similar in design to the steering moment sender G269. It registers the rotor speed of the electro-mechanical power steering motor V187, which is necessary for precise actuation of the motor.

Effects of failure

In the event of failure of the sensor, the steering angle speed is used as a substitute figure. Power steering assistance is shutdown safely. This avoids sudden loss of power steering assistance, caused by failure of the sensor. Faults are indicated by warning lamp K161 lighting up red.



Road speed

The signal for the road speed is supplied by the ABS control unit.

Effects of failure

In the event of failure of the road speed signal, an emergency running program is started. The driver has full power steering assistance but there is no servotronic function. The fault is shown by warning lamp K161 lighting up yellow.

Steering electrics

Engine speed sender G28

The engine speed sender is of the Hall sender type. It is attached inside the crankshaft sealing flange housing.

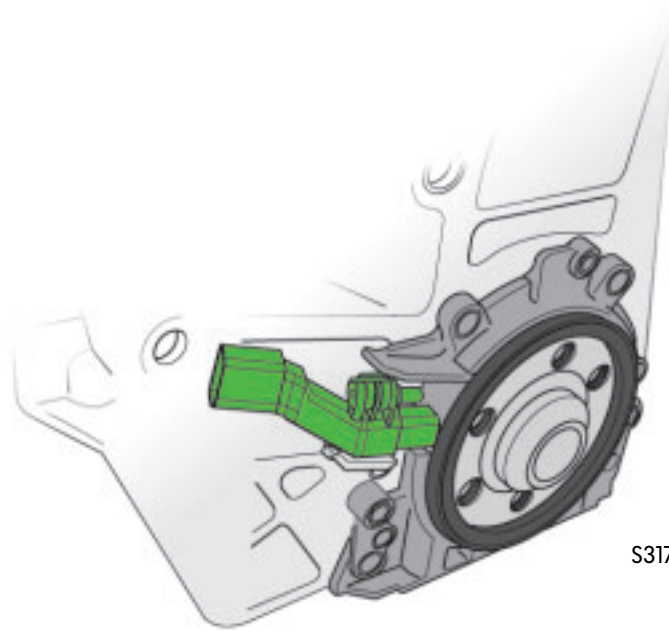

S317_088

Signal application

From the engine speed sender signal, the speed of the engine and the exact position of the crankshaft is registered by the engine control unit.

Effects of failure

In the event of failure of the engine speed sender, the steering is actuated via terminal 15. The fault is not shown by warning lamp K161.



Further information about engine speed sender G28 can be found in SSP 316 "The 2.0 l TDI Engine".

Electro-mechanical power steering motor V187

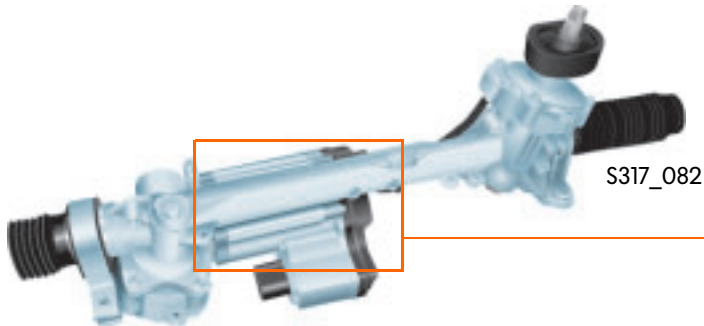

The electric motor V187 is a brushless asynchronous motor. It develops a maximum torque of 4.1 Nm to assist the steering.

Asynchronous motors do not feature a permanent magnetic field or an electrical excitor. Asynchronous motors get their name from the difference between the frequency of the voltage applied and the rotational frequency of the motor. Both frequencies are different, hence the term asynchronous.

Asynchronous motors are simple in construction (without brushes) and, therefore, have a high level of operational efficiency.

Effects of failure

An advantage of the asynchronous motor is that the motor can be moved by the steering gear even in a state of no voltage.

They feature a short response time and are thus suitable for quick steering wheel movements.

The electric motor is installed in an aluminium housing. It engages in the steering rack via a worm gear and drive pinion and thereby transmits the force required for steering assistance.

On the control end of the shaft is a magnet, which is used by the control unit to detect the rotor speed. The signal serves the control unit as a means of determining the steering speed.

This means that, in the event of failure of the motor and thereby loss of power steering assistance, the steering can still be operated by applying a slightly greater amount of force. Even in the event of a short circuit, the motor will not become blocked. Faults are indicated by warning lamp K161 lighting up red.



Steering electrics

Power steering control unit J500

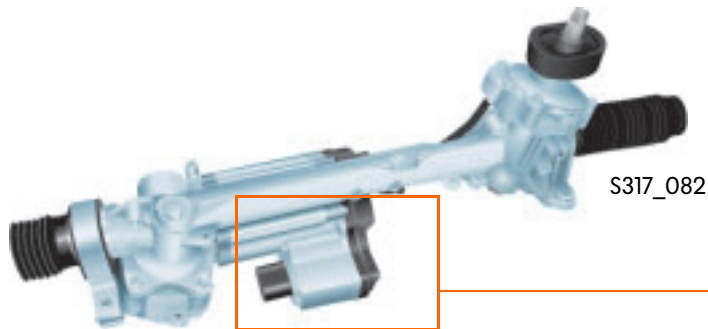

The power steering control unit J500 is attached directly to the electric motor, which means that there is no need for complex routing of wiring to the components of the power steering servo.

Based on the input signals, such as:

- the steering angle signal from steering angle sender G85,
- the engine speed from engine speed sender G28,
- the steering force, the rotor speed,
- the road speed signal and
- the signal that identifies the ignition key as being correct from control unit with display in dash panel insert J285,

the control unit calculates the respective level of force required to assist the steering. The strength of the excitor current is calculated and the motor V187 is actuated.

Effects of failure

Integrated in the control unit is a temperature sensor, which is used to measure the temperature of the steering system. If the temperature rises above 100° C, power steering assistance is reduced gradually.

If the power steering is below a figure of 60%, the electro-mechanical power steering warning lamp K161 will light up yellow and an entry is made in the fault memory.



In the event of a defect in the power steering control unit J500, the component can be exchanged as a complete unit.

The relevant map in the permanent program memory of the control unit must be activated using vehicle diagnosis, testing and information system VAS 5051.

Warning lamp K161

The warning lamp can be found in the display unit of the dash panel insert. It serves as a means of displaying malfunctions or disturbances in the electro-mechanical power steering system.

The warning lamp lights up in two colours if functional faults are detected. If it lights up yellow, the warning is of a lower priority. If the warning lamp lights up red, advice should be sought immediately from a workshop. If the warning lamp lights up red, it will be accompanied at the same time by an acoustic warning signal (three repetitions).



S317_102

When the ignition is switched on, the warning lamp will light up red as part of the self-test procedure carried out by the electro-mechanical power steering system.

Once the power steering control unit receives a signal, indicating that all systems are working correctly, the warning lamp will go out. This self-test lasts for approx. two seconds. When the engine is started, the warning lamp will go out immediately.



Steering electrics

Special features

Towing

Under the following conditions,

- speed greater than 7 km/h and
- ignition switch on,

power steering assistance is also available during towing of the vehicle.



Discharged batteries

The steering system can detect and react to low voltage situations. If battery voltage drops below 9 volts, power steering assistance will be reduced until shutdown and the warning lamp will light up red.

In the case of brief voltage drops below 9 volts, the warning lamp will light up yellow.

Functional diagram

Functional diagram

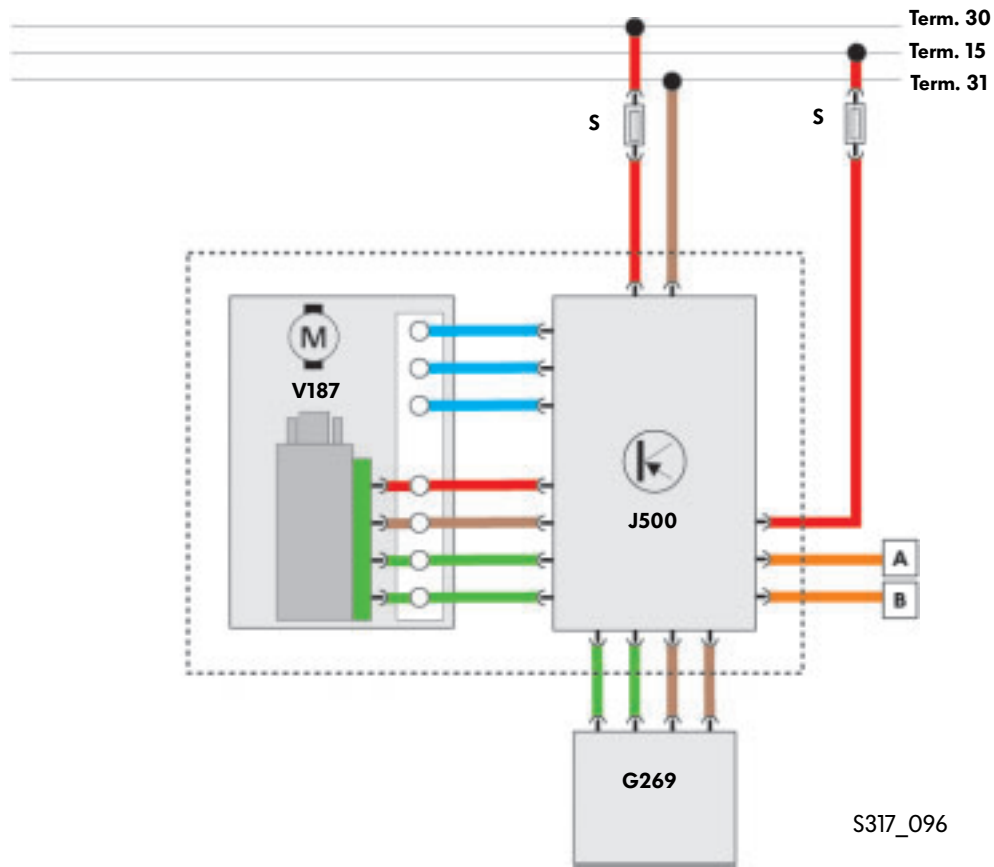

S317_096

- A - CAN low
- B - CAN high
- G269 - Steering moment sender
- J500 - Power steering control unit
- S - Fuse
- V187 - Electro-mechanical power steering motor

Colour codes/key

- = Input signal
- = Output signal
- = Positive
- = Earth
- = CAN data bus



Diagnosis

The system components of the electro-mechanical power steering system are capable of self-diagnosis.

Adaption of steering end stops

To avoid the hard mechanical end stops of the steering, limitation of the steering angle is carried out by the software.

The software-based end stop, i.e. the damping motion, is activated at approx. 5° steering angle before the mechanical end stop.

The assisting force is thereby reduced depending on the steering angle and steering force. Using vehicle diagnosis, testing and information system VAS 5051, the angles of the end stops should be deleted via the "basic setting" function. Adaption is carried out without the tester. To do this, use the information detailed in the latest workshop manual and guided fault finding instructions.



Test yourself

1. Which statements are true?

- a) To assist power steering, an electro-mechanical power steering system is integrated in the steering column.
- b) The electro-mechanical power steering is of the dual pinion design, which is characterised by a steering and drive pinion.
- c) To assist steering, an electro-hydraulic servo is activated.

2. Where is the rotor speed sender located?

- a) It can be found directly on the outside of the electro-mechanical power steering motor V187.
This means there is no longer a need for complex routing of wiring between motor and sender.
- b) It can be found on the steering column between steering column switch and steering wheel.
- c) It is part of the electro-mechanical power steering motor and cannot be accessed externally.

3. What is the function of straight-line stability:

- a) Straight-line stability has the task of balancing deviations on either side of the centre position that occur over a long period of time. For example, deviations that could be caused when summer tyres are changed for winter tyres (used).
- b) With the straight-line stability function, brief deviations from the centre position, caused by constant side winds for example, are corrected.
- c) The straight-line stability function makes it possible to change lanes faster.
- d) When the engine has been started, the electro-mechanical power steering system carries out a self-test. During this self-test, the straight-line stability is corrected, i.e. reset to zero.



4. Name these components

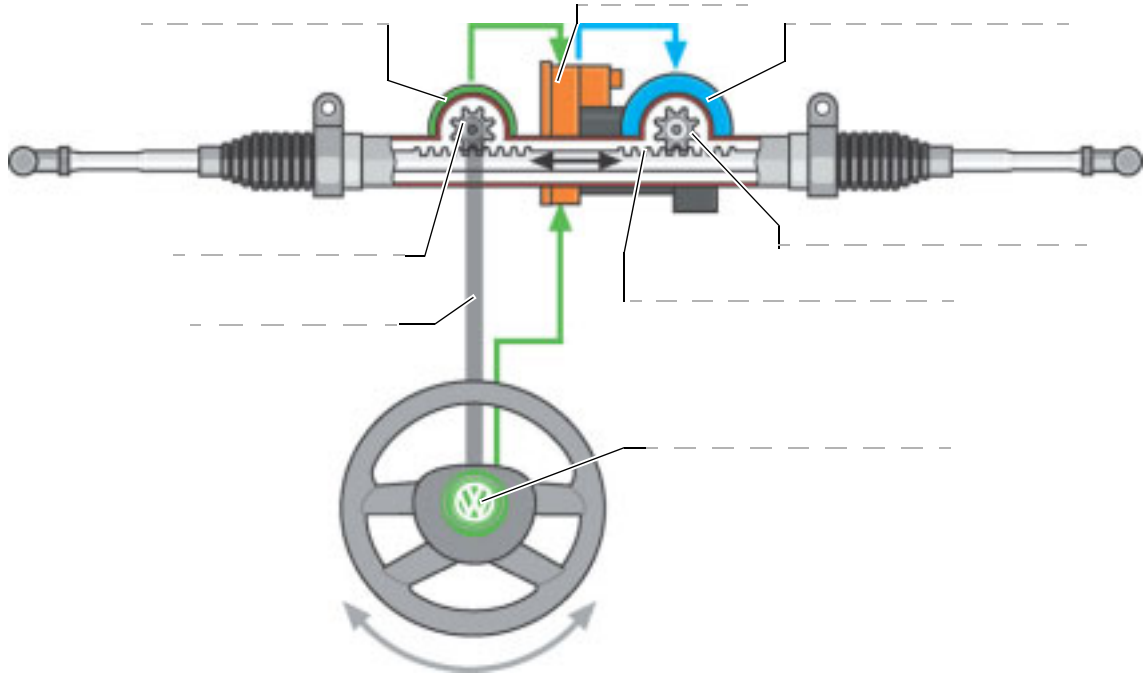

Answers

1.) b

2.) c

3.) a, b

4.) For components, see page 16





© VOLKSWAGEN AG, Wolfsburg, VK-36 Service Training

All rights and the right to make technical alterations reserved

000.2811.38.20 Technical status 09/03

♻️ This paper was manufactured from pulp that was bleached without the use of chlorine.